

ASTR®

Refrigeration Technology

The CE Series

ASTR Refrigeration Technology introduces its heavy duty range of single discharge CE Cabinet Evaporators. "The CE Series"

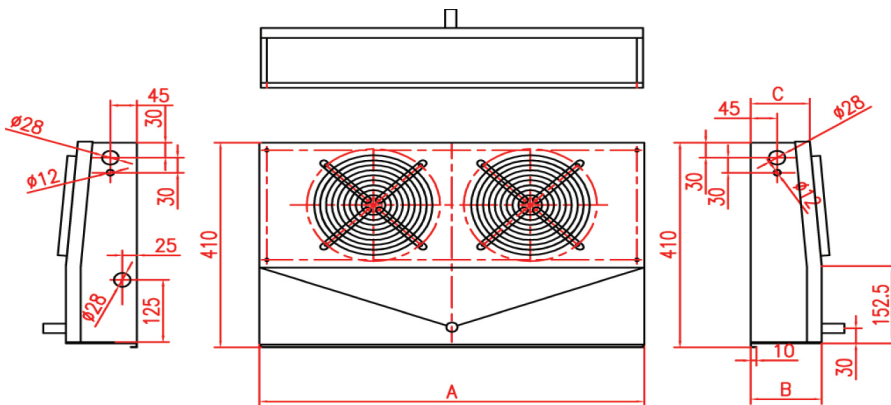

The CE Series

Features & Benefits:

- Heavy Duty Aluminium
- Powder coated internally and externally
- Passivated Fins
- Shaded Pole 3 Piece Fan Motors

Model #	Watts @6KTD		Dimensions			Fans
	R404a	A	B	C		
CE400	400	450	122	102	1	
CE600	600	610	122	102	2	
CE800	800	610	147	127	2	
CE1000	1000	880	147	127	3	
CE1200	1200	880	147	127	3	

		Model	CE400	CE600	CE800	CE1000	CE1200
Capacity @6KTD	R404a	kW	0.40	0.60	0.80	1.00	1.20
SST -4Deg C							
	R134a		0.36	0.54	0.72	0.90	1.08

ASTR®

Refrigeration Technology

ASTR[®]

Refrigeration Technology

The CET Series

ASTR Refrigeration Technology introduces its heavy duty range of Twin Discharge CET Cabinet Evaporators. "The CET Series"

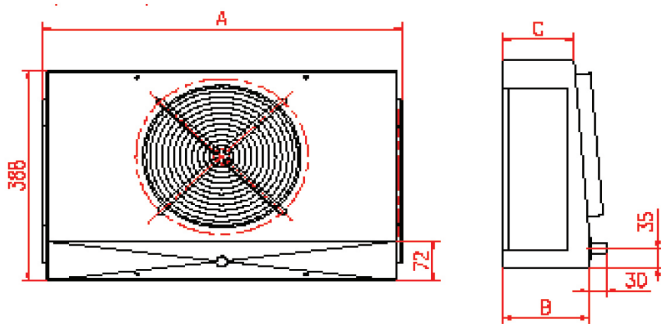

The CET Series

Features & Benefits:

- Heavy Duty Aluminium
- Powder coated internally and externally
- Passivated Fins
- Shaded Pole 3 Piece Fan Motors

	A	B	C	Motor
CET400	602	155	130	1 X 16W
CET600	602	155	130	1 X 25W
CET800	602	155	130	1 X 25W
CET1000	780	177	152	2 X 16W
CET1200	780	177	152	2 X 16W

		Model	CET400	CET600	CET800	CET1000	CET1200
Capacity @6KTD	R404a	kW	0.40	0.60	0.80	1.00	1.20
SST -4Deg C							
	R134a		0.36	0.54	0.72	0.90	1.08

ASTR[®]

Refrigeration Technology